



Schorch Electric Co., Ltd.

Schorch Electric Co., Ltd.

Ultra Clean  
Eco-friendly



Energy Saving  
High Efficiency



# Contents

- 
- 01** Product Qualifications
  - 02** Application Scenarios
  - 03** Frequency Converter Principles
  - 04** Schorch Product Introduction
  - 05** Schorch Product Advantages
  - 06** System Solutions
  - 07** Model Selection





证书号第1139980号



### 实用新型专利证书

实用新型名称：一种逆变器用悬挂结构  
 发明人：请求不公布姓名  
 专利号：ZL 2019 2 2099961.3  
 专利申请日：2019年11月28日  
 专利权人：严国妹

地址：330224 江西省南昌市南昌县梅巷镇渔场68号

授权公告日：2020年09月04日 授权公告号：CN 211423768 U

国家知识产权局依照中华人民共和国专利法经过初步审查，决定授予专利权，颁发实用新型专利证书并在专利登记簿上予以登记。专利权自授权公告之日起生效。专利期限为十年，自申请日起算。

专利证书记载专利登记时的法律状况，专利权的转移、质押、无效、终止、恢复和专利人的姓名或名称、国籍、地址变更等事项记载在专利登记簿上。

局长 申长雨





2020年09月04日

第1页(共2页)

其他事项参见背面

证书号第1139980号

### 利证书

专利号：CN 211423768 U

公告号：CN 211880816 U

初步审查，决定授予专利权，颁发实用新型专利证书并在专利登记簿上予以登记。专利权自授权公告之日起生效。专利期限为十年，自申请日起算。



专利证书的转移、质押、无效、终止、恢复和专利人在专利登记簿上。

局长 申长雨



2020年07月17日

证书号第1139980号

### 利证书

专利号：CN 211880816 U

公告号：CN 211880816 U

初步审查，决定授予专利权，颁发实用新型专利证书并在专利登记簿上予以登记。专利权自授权公告之日起生效。专利期限为十年，自申请日起算。



专利证书的转移、质押、无效、终止、恢复和专利人在专利登记簿上。

局长 申长雨



2020年11月06日

证书号第1139980号

### 证书

专利号：CN 216241373 U

公告号：CN 216241373 U

初步审查，决定授予专利权，颁发实用新型专利证书并在专利登记簿上予以登记。专利权自授权公告之日起生效。专利期限为十年，自申请日起算。

专利证书的转移、质押、无效、终止、恢复和专利人在专利登记簿上。

局长 申长雨



2020年11月06日

证书号第16209951号

实用新型名称：一种...  
 发明人：王凯  
 专利号：ZL 2019 2 2099961.3  
 专利申请日：2021年...  
 专利权人：...  
 地址：62900 南路  
 授权公告日：2022年...  
 国家知识产权局依照中华人民共和国专利法经过初步审查，决定授予专利权，颁发实用新型专利证书并在专利登记簿上予以登记。专利权自授权公告之日起生效。专利期限为十年，自申请日起算。

局长 申长雨

证书号第12819941号

实用新型名称：一种...  
 发明人：毛小...  
 专利号：ZL 2021...  
 专利申请日：2020年...  
 专利权人：...  
 地址：62900 南路  
 授权公告日：2021年...  
 国家知识产权局依照中华人民共和国专利法经过初步审查，决定授予专利权，颁发实用新型专利证书并在专利登记簿上予以登记。专利权自授权公告之日起生效。专利期限为十年，自申请日起算。

局长 申长雨

证书号第16343702号

实用新型名称：一种...  
 发明人：甘成杰  
 专利号：ZL 2021...  
 专利申请日：2021年...  
 专利权人：...  
 地址：629000 南路  
 授权公告日：2022年...  
 国家知识产权局依照中华人民共和国专利法经过初步审查，决定授予专利权，颁发实用新型专利证书并在专利登记簿上予以登记。专利权自授权公告之日起生效。专利期限为十年，自申请日起算。

局长 申长雨

证书号第11614197号

实用新型名称：一种...  
 发明人：丁东旭  
 专利号：ZL 2019 2...  
 专利申请日：2019年12...  
 专利权人：...  
 地址：430077 湖北(武汉)北园  
 授权公告日：2020年10...  
 国家知识产权局依照中华人民共和国专利法经过初步审查，决定授予专利权，颁发实用新型专利证书并在专利登记簿上予以登记。专利权自授权公告之日起生效。专利期限为十年，自申请日起算。

局长 申长雨

证书号第3035333号



### 发明专利证书

发明名称：一种变频器  
 发明人：王海涛;李珂;姚尧;彭映杰;袁昊强;马晓光;陈强  
 专利号：ZL 2016 1 1002910.9  
 专利申请日：2016年11月10日  
 专利权人：成都信息工程大学

地址：610225 四川省成都市双流县西南航空港经济开发区学研路一段24号

授权公告日：2018年08月14日 授权公告号：CN 106452102 B

本发明专利依照中华人民共和国专利法进行审查，决定授予专利权，颁发本证书并在专利登记簿上予以登记。专利权自授权公告之日起生效。

本专利的专利期限为二十年，自申请日起算。专利权人应当按照专利法及其实施细则规定缴纳年费。本专利的年费应当在每年11月10日前缴纳。未按规定缴纳年费的，专利权自应当缴纳年费期满之日起终止。

专利证书记载专利登记时的法律状况，专利权的转移、质押、无效、终止、恢复和专利人的姓名或名称、国籍、地址变更等事项记载在专利登记簿上。

局长 申长雨



2018年08月14日

第1页(共1页)

其他事项参见背面

## MV Frequency Converter Products— Major Industry Applications and Application Loads

### Applications in a Diverse Range of Industries



**Cement Manufacturing**  
Kiln induced draft fan,  
preheating tower fan,  
cooler exhaust fan, pressure blower,  
raw meal grinding induced draft fan,  
classifier fan, main dust suction fan,  
cooler dust suction induced fan, etc.



**Thermal Power Generation**  
Feed water pump, dust suction fan,  
centrifugal induced draft fan,  
mortar machine, blower,  
circulating water pump,  
axial-flow induced draft fan with  
adjustable static blades  
compressor, etc.

**Mining and Metallurgy**  
Sintering main exhaust fan,  
mud Pump, high pressure blower,  
cooling water pump, descaling pump,  
centrifugal feed pump,  
blast furnace fan, compressor, etc.



**Petroleum and Chemical Industry**  
Main pipeline pump,  
water injection pump,  
mixer, gas compressor,  
extrude, brine pump,  
submersible oil pump,  
boiler feed pump, etc.



**Water Supply and Sewage Treatment**  
Sewage pump,  
purification pump,  
fresh water pump,  
biological rough treatment tower  
pump, etc.



**Others**  
Transmission machinery,  
wind turbines,  
wind tunnels, etc.



## Principle Introduction of the Converter

### Introduction of converter technology

The converter is a power control device that converts the power supply of industrial frequency into another frequency by using the on-off function of the power semiconductor device, which means to convert the industrial frequency power (50Hz or 60Hz) into AC power of various frequencies to change the speed of motor.

After the 1960s, especially since the 1970s, the rapid development of power electronic technology, control technology and microelectronics technology has made the performance of AC speed regulation comparable to that of DC speed regulation. At present, AC speed regulation has entered the era of gradually replacing DC speed regulation. The excellent performance of frequency conversion speed regulation in speed regulation range, speed regulation accuracy, dynamic response, low-speed torque, communication function, intelligent control, power factor, saving electric energy, working efficiency, convenient use, etc. is unmatched by other AC speed regulation methods.

The MV converter adopts the current international popular multilevel technology of power unit series connection, and the system is of medium-medium structure. The MV power is directly input into the converter, and after rectification and inversion by the converter's internal power system, the MV power inverter will be directly output to the motor, no need for step-up transformers and other components.

Each power unit is a PWM LV converter with three-phase input and single-phase output, with reliable technology, completely consistent structure and performance, which greatly improves the reliability and maintainability of the MV converter. By adopting the overlapping wave technology, the harmonic content in the output voltage of the MV converter is eliminated to the maximum extent, and the voltage waveform is close to the standard sine wave, which greatly improves the output performance of the converter.

## Converter drive system diagram

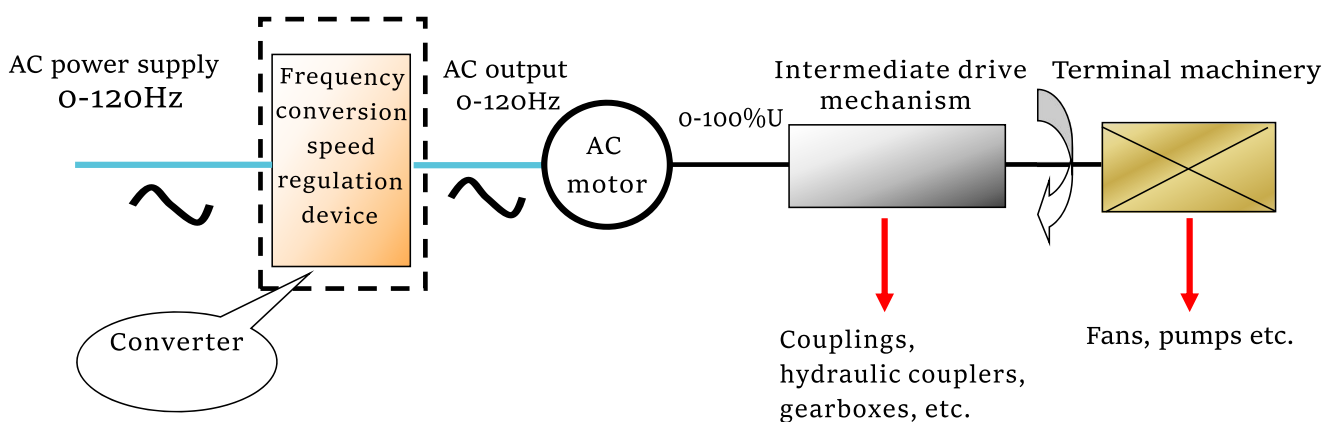

**Frequency Conversion Transmission System Model**

Converter Principle - System Schematic Diagram

Adopt the plan of multi-level and VSC **Power component: IGBT**

Take converter of 6kV as an example

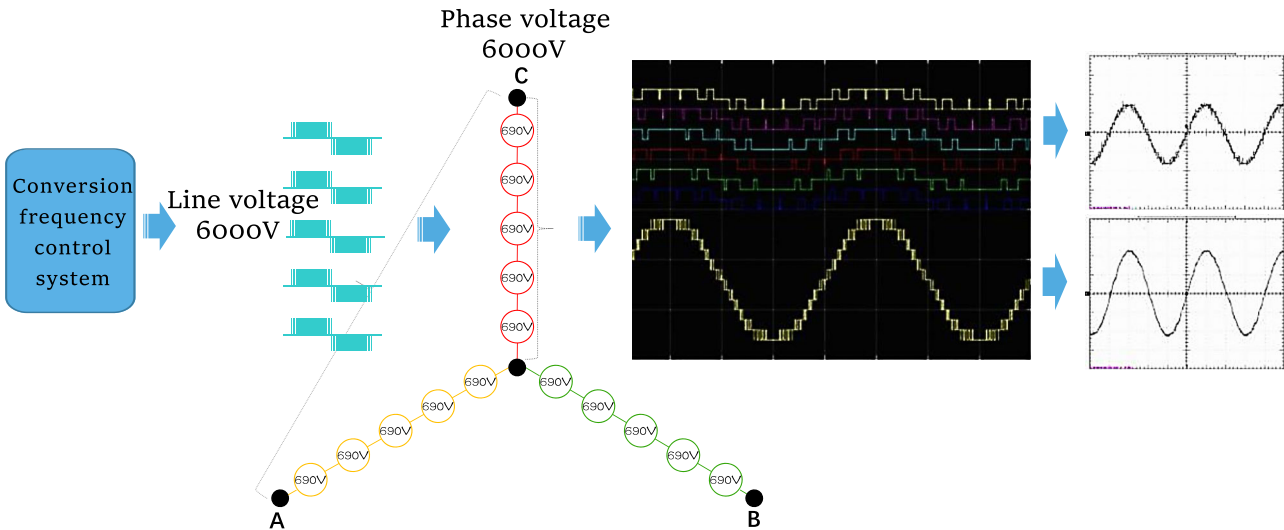

Converter Principle - Power Unit Schematic Diagram

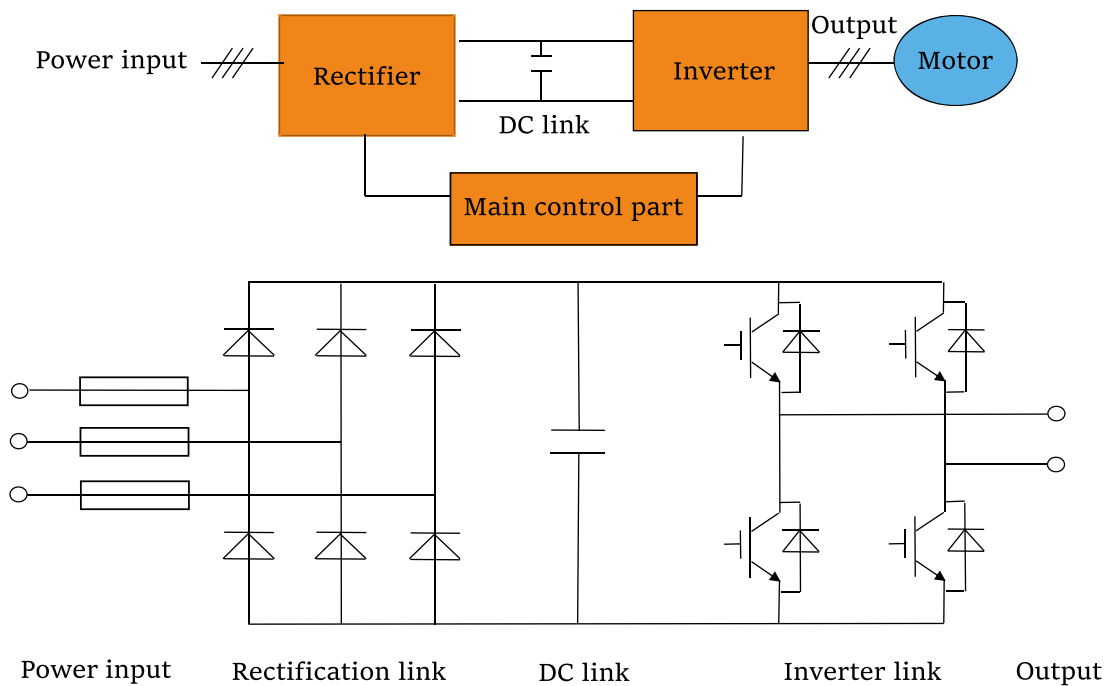



### Converter Principle - System Structure Diagram

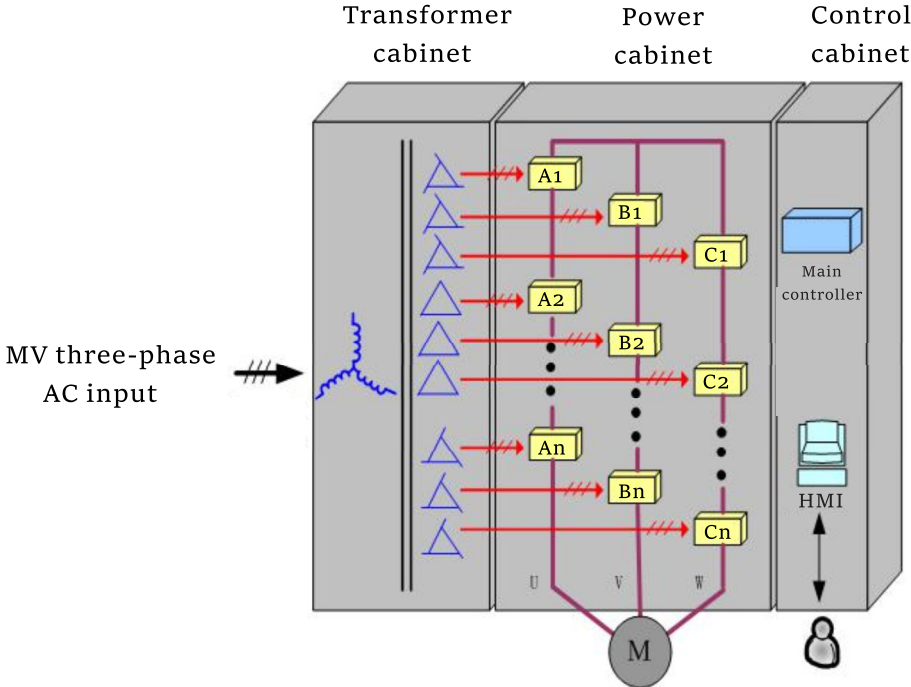

MV Converter System Model

### Converter Principle - Topology

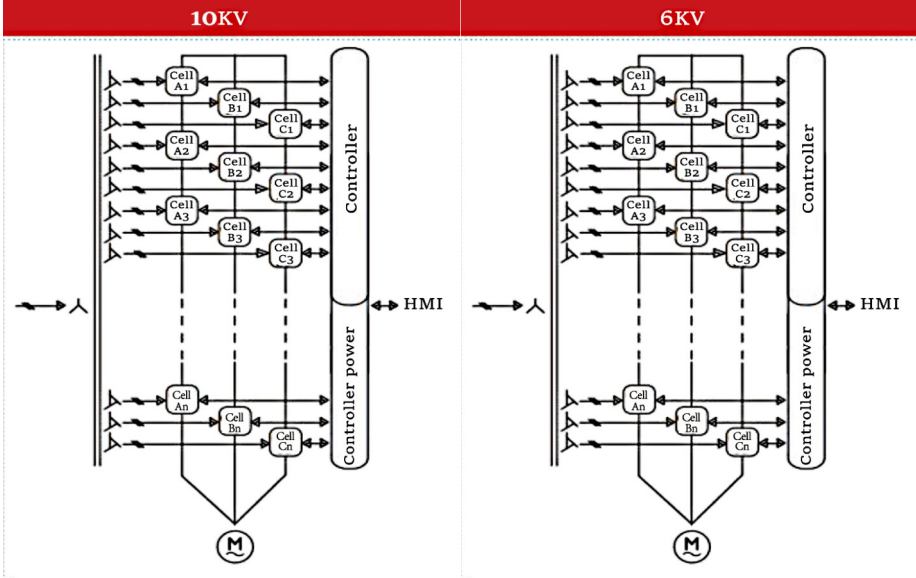

## SCHORCH Series Product Classification

### Classification of MV converter

- Fan and pump Loads – general type.
- Connected to grid at starting of converter - synchronous grid connection type.
- Loads of hoists etc. working under power generation station - energy feedback four quadrant type.
- Belt conveyor load application - multi-motors drive, power balance type.
- Low-speed direct-connect synchronous motor-low-speed direct four-quadrant frequency conversion.
- Super high power series above 10MW(water cooling).
- For the tight indoor space intensive design(container structure).

## Energy Saving Principle

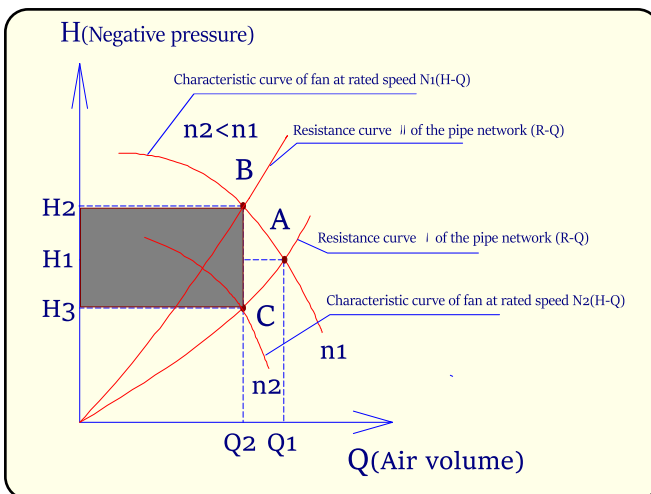

Energy-saving Curve of Converter

The characteristic curve of the fan is changed by reducing the fan speed and the air volume;  $n_2$  is a family of curves parallel to the rated speed to maintain the original high efficiency. The intersection point C is the working point at this time; when the frequency conversion speed regulation reduces the flow, the pressure for conveying this flow is also reduced to  $H_3$ , which is an energy-saving adjustment, the pressure is used for useful work, which greatly reduces the waste of energy.

### 1. Adjustment of damper or valve

Increasing the resistance of the pipe network makes the resistance curve of the pipe network become "the resistance curve II of the pipe network" and the intersection point B becomes the working point at this time; the shaft power required by the fan is  $P=(H*Q)/1000\eta$ , which is an energy-consuming way to adjust the air volume. The energy consumption of the fan has not been greatly reduced due to the substantial reduction of the air volume.

### 2. Frequency conversion speed regulation



### SCHORCH Products Introduction



**Transformer**



Encapsulation structure  
Dry air cooling  
Phase shifting and voltage transformation

**Power unit**

One-sided maintenance  
Optimized organization  
High power density



**PLC**

Adopts TI-DSP chip  
Digital control  
Support multiple communications



### SCHORCH Products Introduction-Power Unit Display



**Air-cooled Power Unit**



**Water-cooled Power Unit**



**Power Supply Unit**

Product Series

Schorch Series

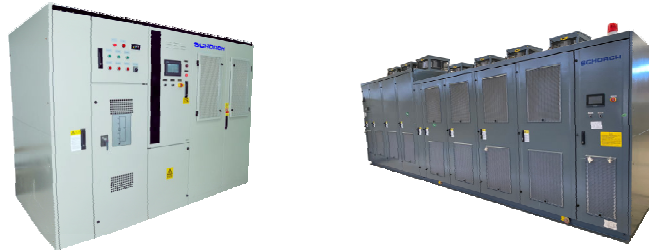

Universal Frequency Converter	Current range	58A	100A	600A	900A	2300A
	Air-cooled series	<900A				
	Water-cooled series	<2300A				
	Four quadrants	<900A				

SCHORCH Product

Introduction of forced air-cooled converters

**Overview:** the capacity ranges of forced air-cooled converters are 250KVA-15MVA. They adopt the modular assembly design of power units and air-cooled method of the power unit, with features of high-power density and easy for maintenance and installation. They are suitable for LNG, wind tunnel, long-distance pipeline, chemical industry, metallurgy, power generation, cement and other fields.

Product Parameter	Product Display		
<ul style="list-style-type: none"> <li>Voltage: 10 KV</li> <li>Capacity: 10000KVA</li> </ul>			
<p>Product Features</p> <ul style="list-style-type: none"> <li>High reliability</li> <li>Long service life</li> <li>IGBT Optical fiber drive</li> </ul>			



**SCHORCH 10KV Air-cooled Series**

**Introduction of water-cooled converter products**

Overview: the capacity ranges of high-power water-cooled converters are 7000KVA-40MVA. They adopt the modular assembly design of the power unit and water-cooled method of the power unit, with features of high power density and easy for maintenance and installation. They are suitable for LNG, wind tunnel, long-distance pipeline, chemical industry, metallurgy, power generation, cement and other fields.

**Products Parameter**

- ▼ Voltage: 6-13.8KV
- ▼ Capacity: 10-40MVA
- ▼ Power: 10-32MW

**Products Display**



**Products Features**

- ▼ Quick insertion design
- ▼ Flexibility arrangement
- ▼ Remote monitoring



**SCHORCH 10KV Water-cooled Series**



## Water Circuit of Unit Cabinet

Schematic Diagram

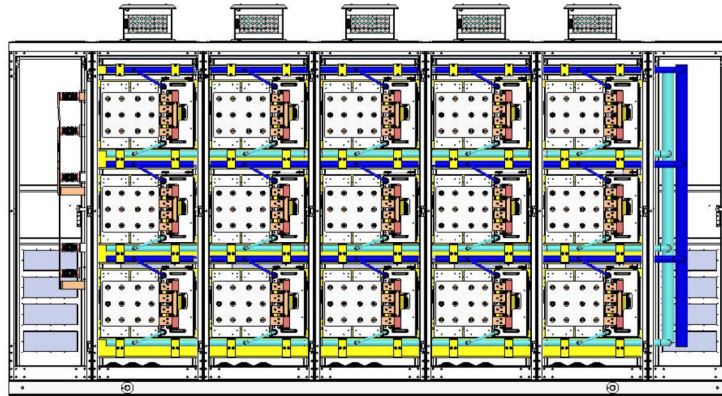

### Parallel Design of Dual Waterway

Independence of rectifier and inverter cooling water circuits, with high heat dissipation efficiency.

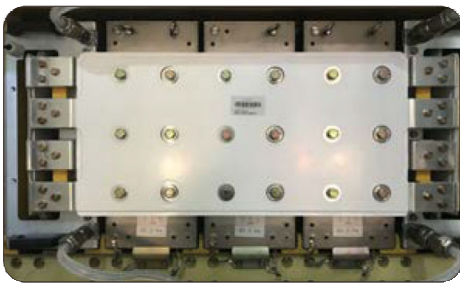

### Waterway Direction

Reasonable waterway design and easy maintenance.



### Using of MV Power Devices

Simplify the main circuit by using 3300V/4500V IGBT devices.

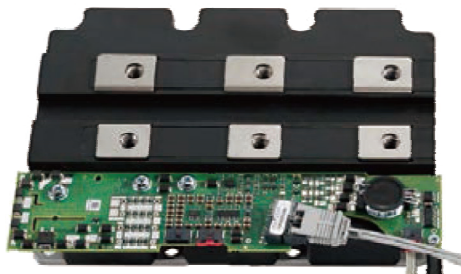

### On-line Plugging/Unplugging of Water Connections

All modules are equipped with quick connections for inlet and outlet of the water pipes, which can be plugged and unplugged online for convenience of the maintenance and replacement of the converter power unit.

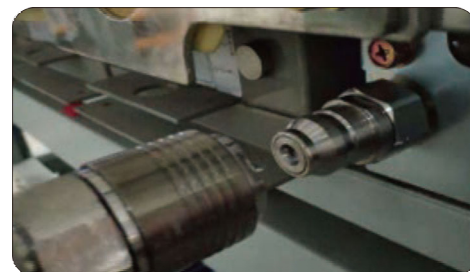

**Technical parameters of water cooling system**

Name	Parameters
Cooling medium	Pure water ethylene glycol
Maximum allowable water supply	5 bar
Conductivity value of cooling water	<=0.5μs.cm-1
Water supply temperature	10~40°C
Return water temperature	18~47°C
Filtering accuracy of main circulation	<=3.5bar
Pressure loss of cooled device at rated	200μm
Filtration accuracy of deionization	10μm
Design pressure of water cooling	10bar

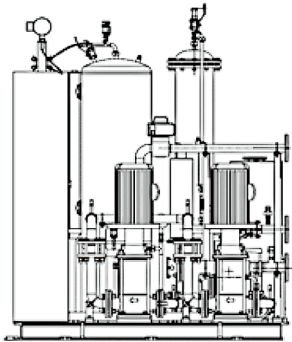

**Cooling Water Flow Calculation**

Thermal principle formula  $Q=Cp \times P \times Vs \times \Delta t$

Q.....calorific

Cp.....specific heat at constant pressure(J/kg°C)

P.....density(kg/m3)

Vs.....flow(m3/h)

Δ t.....temperature difference ( C )

**Secondary Heat Exchange Mode**

There are two types: water -air heat exchange and water-water heat exchange.

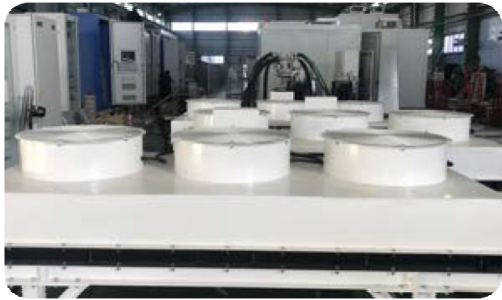

**Water Quality Requirements**

- Internal water parameters:  
Ultra pure water with conductivity <=0.5μs.cm-1 , provided by water machine manufacturer.
- Outer water parameters:

Name	Parameters
Inlet water temperature	5~35°C
Temperature difference between inlet and outlet	7°C
Flow	Over water machine flow
Inlet pressure	3~10bar
Suspended matter	<=30mg/L
PH value	6.5-7.5
Hardness	15-30PPM



## Introduction of Special Power Supply Converter



### Frequency Power Supply

#### Products features

Rated voltage of system: 10KV/6KV  $\pm$  15%

Output voltage: various voltage levels from 440V~13.8kV

Output power: 0-120Hz

Output capacity: 0-25MVA

Rated output current of system: 0~1400A

Protection level: IP54/31/20

Converter efficiency:  $\geq$  96%

Power factor at input side:  $>$  0.95

Sine distortion rate of output voltage waveform:  $<$  3%

Harmonic voltage factor: HVF  $\geq$  0.003

Overload capacity: 120% for 1min, Instantaneous protection for 150% (supporting customized design)



## Special Function Introduction

### Soft Charging Technology

The closing surge of high-power transformer is an important aspect to consider and take measures to solve in the design of our system. When the voltage of the transformer recovers after unload switching-on or external fault elimination, the iron core of the transformer will be seriously saturated because the magnetic flux in the iron core cannot change abruptly. At this time, a large impact current, i.e. excitation inrush current, will appear in the transformer coil. The magnitude of the transformer excitation inrush current is closely related to the saturation degree of the transformer iron core. The more saturated the iron core is, the greater the inrush current will be. The amplitude of the excitation inrush current can reach 6-8 times of the rated current of the transformer. Although it has no direct harm to the transformer itself, it is easy to cause malfunction of the relay protection device of the transformer. Especially, in order to improve the efficiency, the working magnetic flux density of large-capacity transformer is designed to be very high, which will be even more serious. We adopt the low-voltage reverse charging pre-magnetizing scheme, which can effectively eliminate the inrush current generated during power-on and reduce the impact on the power grid by charging the transformer in advance with low voltage.

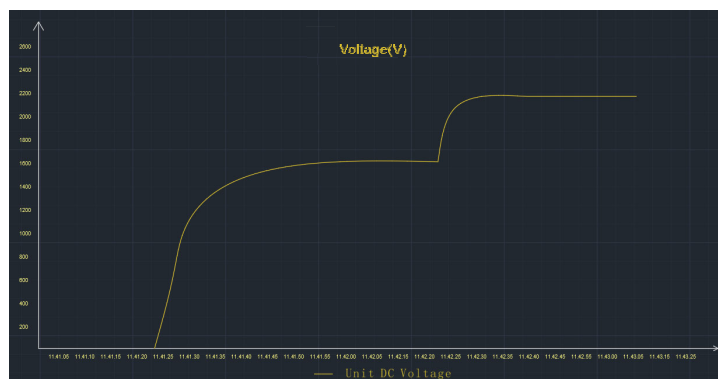



### Analog Output Indication

The converter has four channels of 4 - 20 mA analog output interfaces for output voltage, output current, output power, and output frequency. The maximum displayed range of each analog channel can be modified on the touch screen to adopt the requirements of the user's meter head.

The accuracy of the converter output analog can meet the user requirements under the operating ambient temperature, and the fluctuation range of output signal is within the scope of -0.25% ~ +0.25%.

### Closed Loop Control

The detection value of sensor feeds back a 4-20 mA signal to the frequency conversion speed regulating device, and the closed loop controller will automatically adjust the output frequency of the frequency conversion speed regulating device according to the feedback value, to keep the pressure and other variables of external equipment at a constant value.

Just take the water pressure as an example, the Schorch MV frequency converter can set the required pressure value on the display screen. During operation of motor, the converter can automatically adjust the frequency and amplitude of the output voltage of the converter to keep the water pressure within the scope of set pressure value. This function needs to set parameters according to the special requirements of the site.

### System Bypass

When the converter fails, we can bypass the converter and directly connect the motor to the original grid to keep the operation of motor. There have two types of bypasses: automatic bypass and manual bypass. Manual bypass requires manual operation and takes a long time, and is suitable for operation without a backup device or under unimportant operation conditions. While the automatic bypass can be used to switch to industrial frequency operation directly after the failure of the converter. The system can realize the fast switching of industrial frequency/ frequency conversion by using the function of flying start. The user can select "Allowed" or "Forbidden" for the bypass of failed system. If "Allowed" is selected, the system will automatically switch to industrial frequency to continue operation when a fault occurs during operation; If "Forbidden" is selected, the system will stop freely after a fault occurs.

### Dual Power Supplies

The control power supply of the MV converter adopts dual power supply technology, one is from the user's on-site low-voltage power, the other from the secondary side of the transformer. The two power supplies are hot standby for each other. With the operation of equipment, the power failure of any control power supply will not affect the equipment, and there is no switching problem after the control power is cut off. It can provide a control power of 3-phase 380V on site, with a capacity requirement is not less than 10kVA, which completely solves the problems of unreliable power supply and short supporting time of UPS. When the external AC control power supply is power off, the converter can still operate stably for a long time. The internal power supply system of the converter adopts DC power supply.

### Flying Start-up

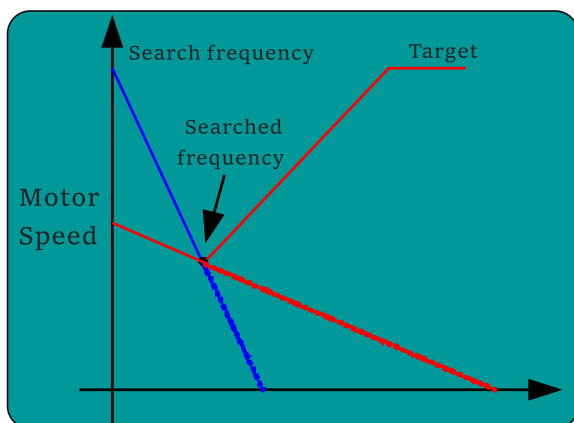

The converter has a flying start-up function, which can ensure that the motor can be started directly without impact at any speed within the speed regulation range without stopping. It is possible to ensure the normal tracking of the actual motor speed for starting while the motor is still rotating.

The DSP vector control technology is used to identify the motor speed quickly and shorten the start-up time to meet the field process.

At starting, the converter outputs a low voltage and the frequency gradually decreases from 50 Hz, while the output current is detected. When the output current reaches a certain value (equal to the pre-set value), the corresponding output frequency is the motor rotation frequency.

After the converter has searched the actual speed of the motor, the control system will directly output the corresponding frequency and voltage at the speed. After the motor runs smoothly, it will return to the given frequency according to the set acceleration time and operate normally.

Advantages of SCHORCH Converter Technology

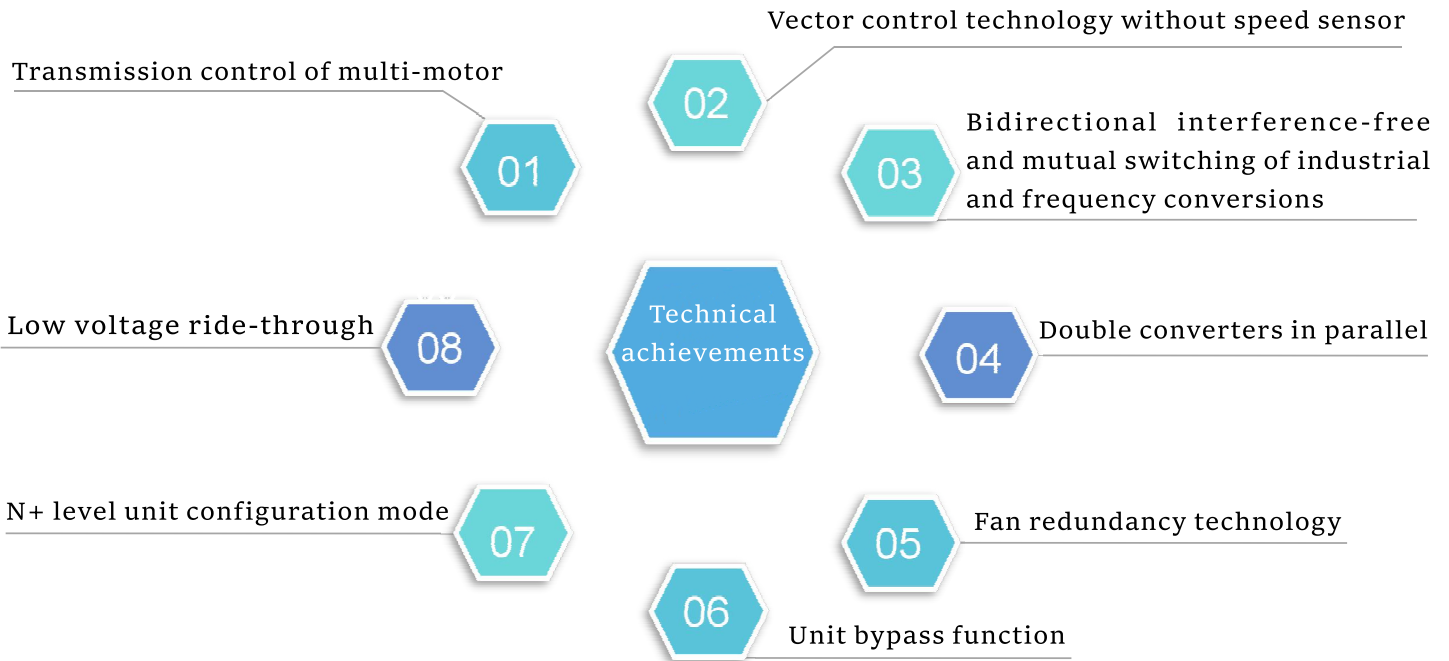

1

Transmission Control of Multi-motors

Technical features:

- Adopt vector control technology without speed sensor.
- Adopt optical fiber communication control technology to realize data transmission between converters.
- Realize power balance distribution without external coordination device.
- Set the master-slave devices arbitrarily, with flexible operation.
- Consistent configuration of master and slave devices for easy maintenance.

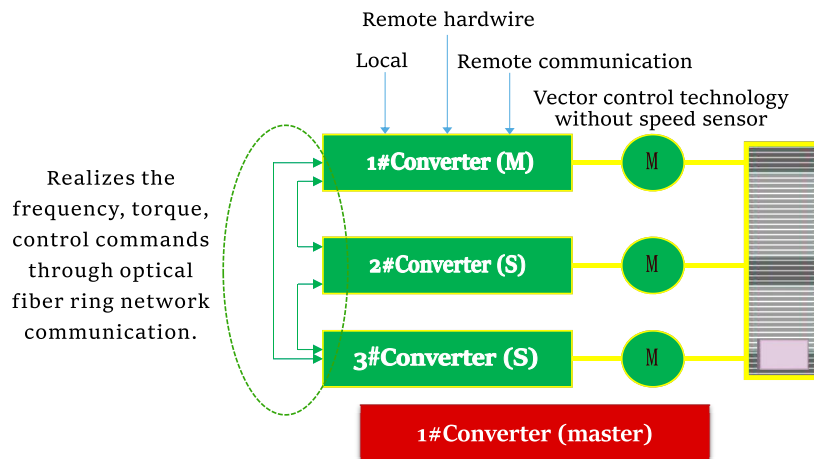

## 2

## Vector Control

- **Vector control function without speed sensor**

Transitionally, the V/F control method is adopted, which has poor control accuracy, poor current control ability in the start-up process, and lower motor running stability than vector control.

- **Advantages**

The MV frequency conversion speed regulating system of Schorch Electric adopts the self-developed high-performance speed vector control mode without speed sensor, which has the advantages of large starting torque, strong resistance to load fluctuation, high control accuracy and so on, and has many achievements in high-power products.

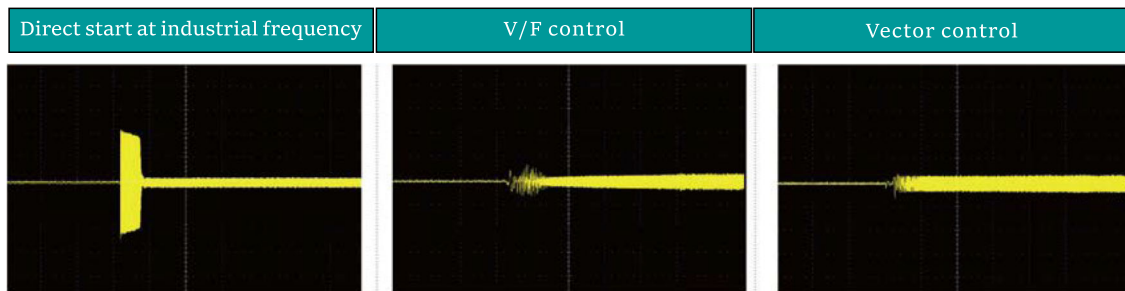

## 3

### Bidirectional Interference-free and Mutual Switching of Industrial and Frequency Conversion

- Realize the free switching of the operation of motor from frequency conversion to industrial frequency or from industrial frequency to frequency conversion.
- Self-adaptation and no impact in the process of synchronization.
- Support the synchronous grid connection and switchback control of VF and vector.
- Solve the problem of soft start and switch-back speed regulation of high-power motor.

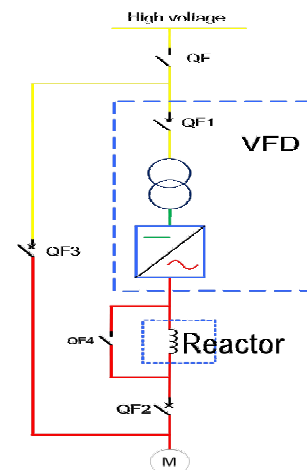



04

## Double Converters in Parallel

Technical features:

- Realize converter expansion.
- Realize hot standby of converters.
- Motors can keep operating with failure of single converter.
- Switched back to parallel operation without stopping after the faulty converter is restored.

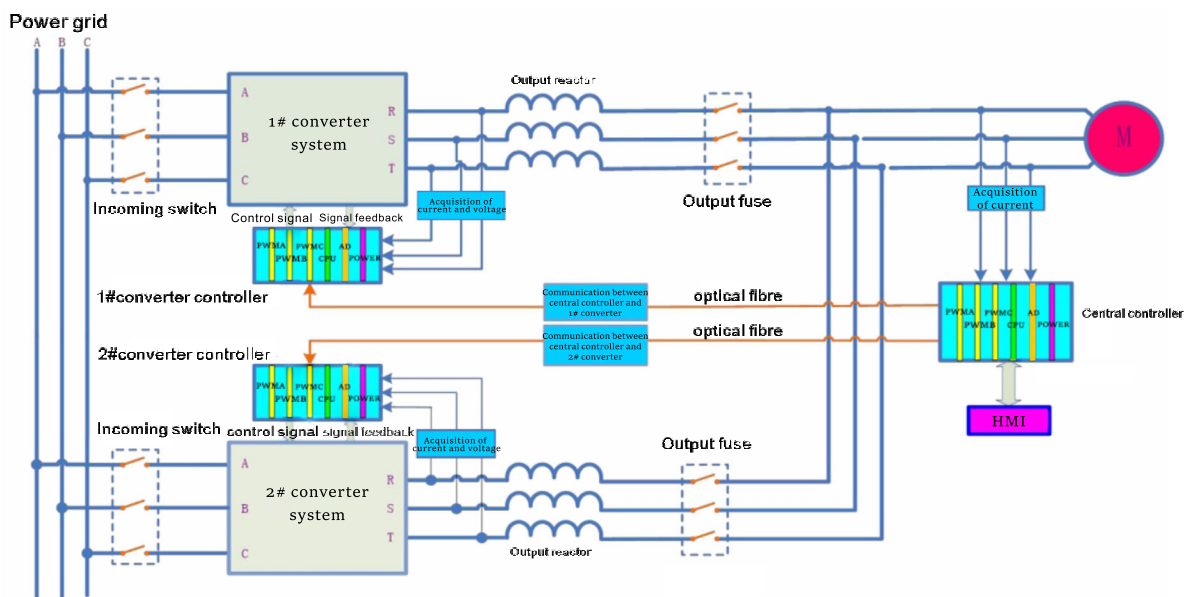

5

## Fan Redundancy Function

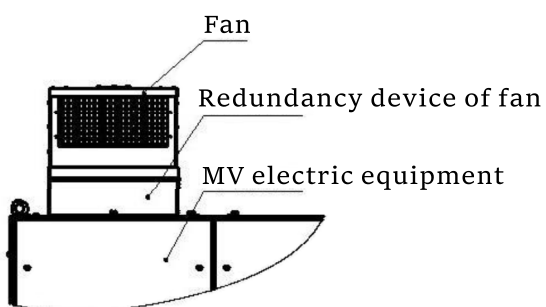

Technical features:

- Fan status monitoring alarm.
- The converter can keep running with damaged fan.
- The converter can accurately locate the fault position of the fan.

6

## Unit Bypass Function

Technical features:

- Adopt neutral point drift control technology;
- Each phase supports up to 2 levels of bypass;
- It is recommended to use the same level of bypass abroad.

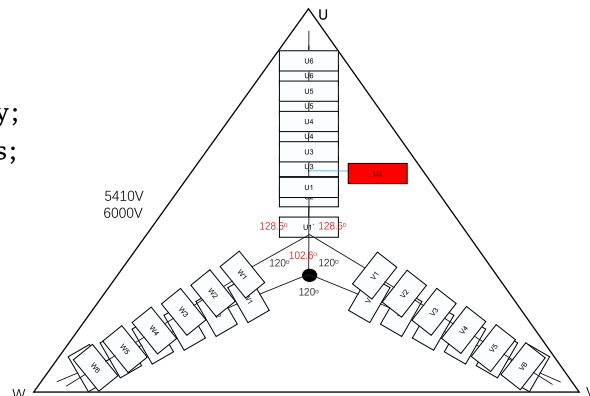

7

## N+ Level Unit Configuration Mode

At present, the domestic MV converters mostly adopt the structure of multi-level series voltage source or current source. Due to various reasons such as IGBT withstand voltage level, the number of power unit levels of MV converters is always limited to the inherent mode of 6KV-5 levels and 10KV-8 levels. Because the maximum output voltage of a single unit module can only reach 690V, according to the principle of series boosting, taking 6KV as an example, the phase voltage when the 5-level unit is connected in series is 3450V, and the line voltage is 6,000 V at star output. As the power unit modules work at high frequency for a long time, they have a certain failure rate, so major manufacturers developed the unit bypass function in the early stage to avoid the most failures of unit modules. However, due to the limitation of the number of inverter levels, the number of bypassable units is limited, otherwise, the converter will need to run at reduced capacity, which cannot meet the on-site process requirements. Our company proposed the N+ level unit series topology structure as early as 2008. Through unremitting efforts, the current maximum can be increased to 16 levels, which means that the 10KV equipment can still output at full load even if half of the unit modules fail, and the stability of the MV converter has been improved for several times. However, due to the large number of units, the maximum output voltage of the equipment is limited during normal operation. At this time, the controller controls the output of all unit modules to reduce the capacity, and the equipment's requirements for single high-frequency devices are reduced, which greatly reduces the unit IGBT failures caused by high-frequency control, and makes the stability of the equipment much higher than that of standard equipment.

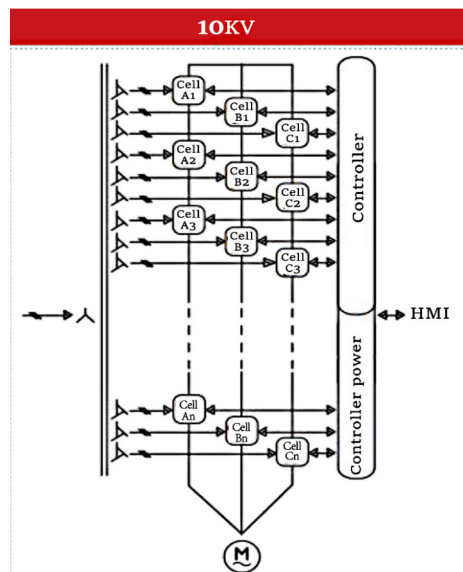

8

### Low Voltage Ride-through

Grid voltage

Output voltage

Output current

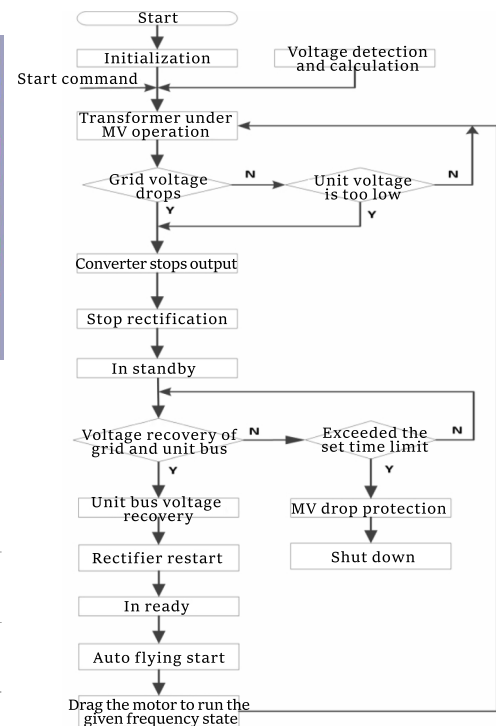
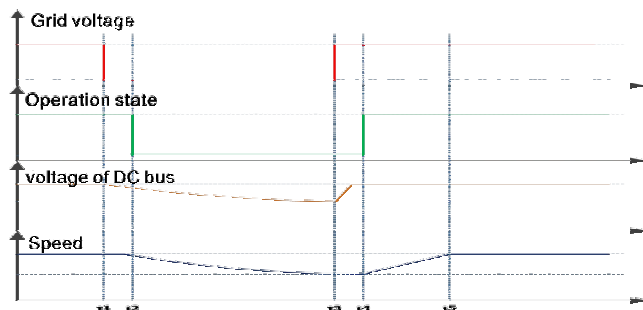
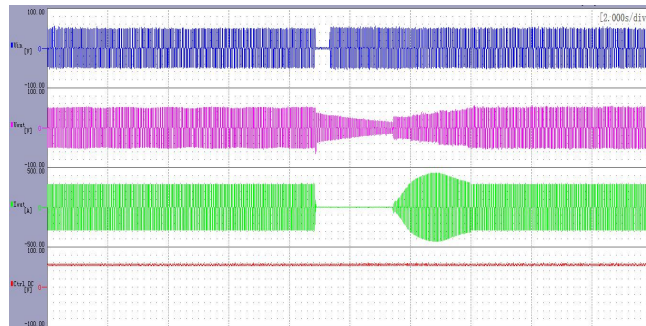

The converter can start automatically and buffered by kinetic energy when the power supply is instantaneously powered off and then restored. The time is related to the specific load and has been verified by a third-party organization. When the voltage drop of input power supply of the converter is within 10% of 10kV, the motor can work continuously and normally at the rated load (without changing any wiring and setting), and the output voltage of the converter is basically remains unchanged at 10kV; When the input voltage of 10kV supply suddenly drops by 10%-40%, the converter will automatically perform capacity reduction operation according to the current input voltage, and automatically return to the working condition before capacity reduction When the input voltage of 10KV power supply returns to 10%; When the input voltage of 10KV supply suddenly drops below 60% or the power is restored after the power grid is flashed (for 3S): the converter can automatically restore to the operating condition before power failure.



System Scheme

Scheme of one for one + manual bypass  
10KV MV bus

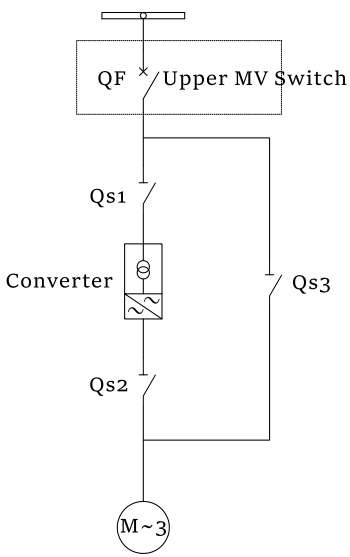

Scheme of one for one + manual bypass  
10KV MV bus

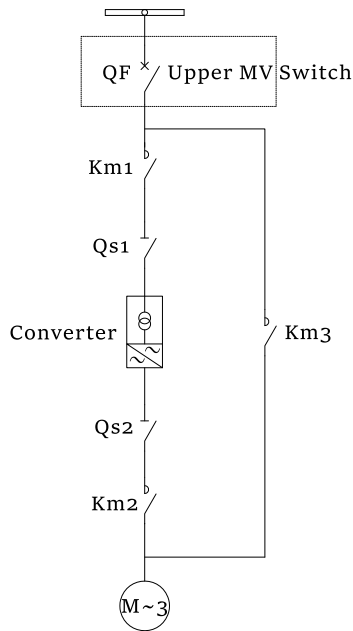

Scheme 1 of one for two

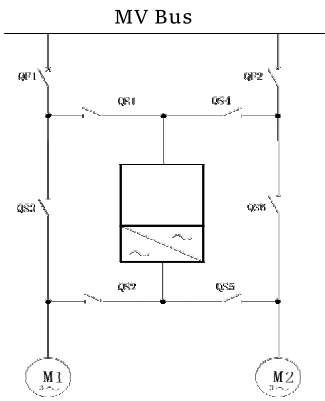

Scheme 2 of one for two

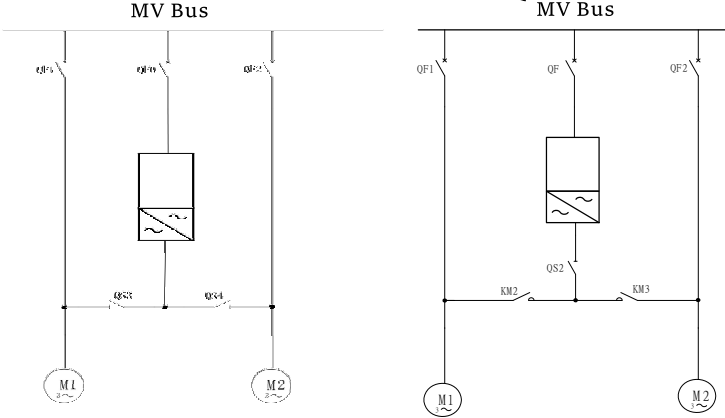

Common grid-connected schemes for converter starting

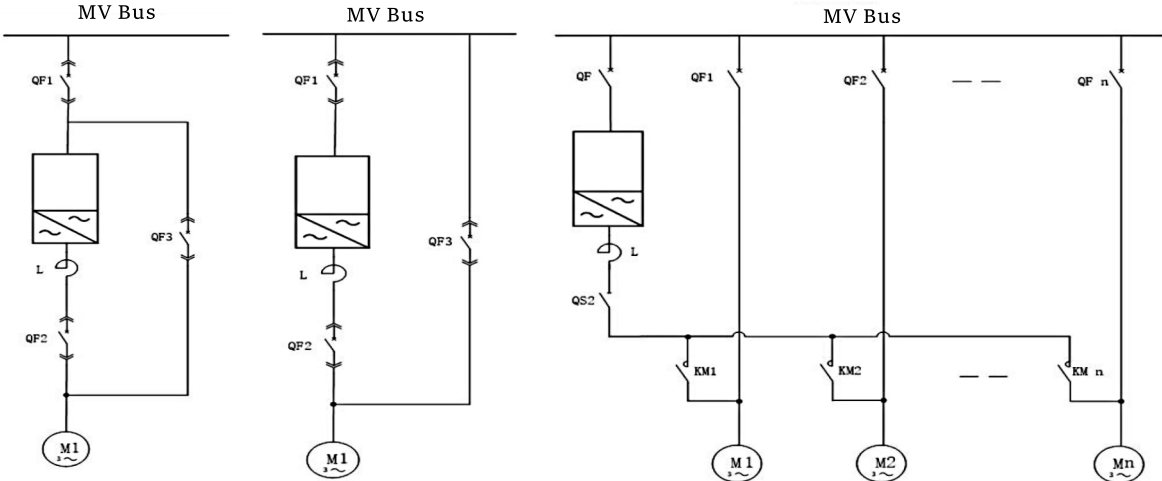

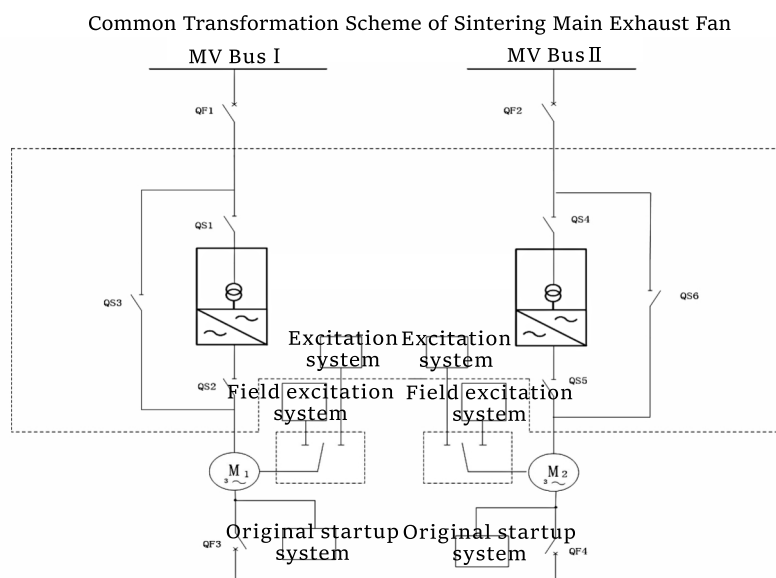

## Advantages of Converters

The appearance of the converter has brought about a technological revolution in the field of industrial control.

- It has reduced the impact of the power grid when the equipment is started.
- It has replaced the original backward speed regulation technology, with more precise of speed regulation and larger regulation interval.
- It Improves the degree of automation control of the system; improves the security protection performance of the system.
- It reduces the equipment operating costs; extended equipment service life; with smoother pressure or air volume at startup.
- It realizes the stepless speed regulation, with wide frequency adjustment range, from 0-rated frequency, adjustable at will.
- It has high adjustment precision, energy saving, improved process control and product quality.
- It realizes the automatic control of the motor, such as turning off, stopping, rotating forward and backward, adjusting the motor speed, etc.
- Full digital control, easy to realize networked and automatic control.
- It realizes the soft start of the motor, with small starting current limited under the rated current, and the impact on the power grid is small. Small impact on the motor during startup to reduce the insulation loss and prolong the service life.
- It cancels the hydraulic coupler to improve the use efficiency.
- It reduces the fan surge or water hammer effect of water pump.
- It reduces the operating speed of the mechanical system, which effectively reduces the mechanical wear; Compared with the traditional speed regulation method, it is convenient to maintain and greatly reduces the maintenance cost; The harmonic is small after the converter is put into operation, which reduces the pollution to the power grid.

## Application of Frequency Conversion Direct Drive System on Belt Conveyor

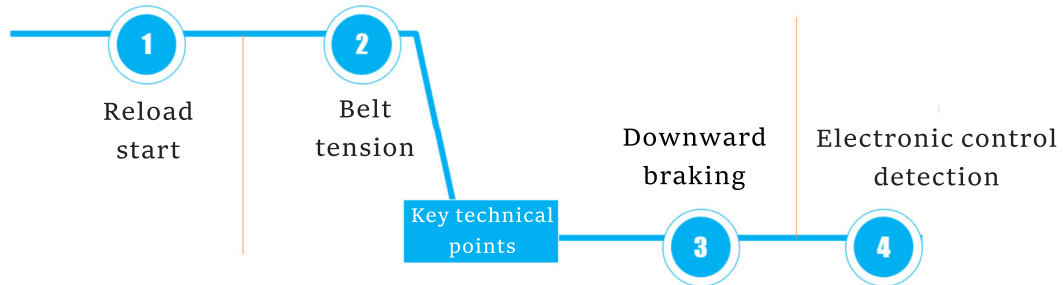

## Solutions of Downward Braking

In the four-quadrant converter, the IGBT power module can realize the bidirectional flow of energy, the IGBT is used as the rectifier bridge, and the DSP with high speed and high computing power is used to generate the SVPWM control pulse. On the one hand, it can adjust the input power factor, eliminate the harmonic pollution to the power grid (the total harmonic content of the converter is less than 4%), and make the converter truly become a "green product". On the other hand, the energy generated by the motor feedback can be sent back to the grid.

Under the normal operation of the belt, the converter absorbs energy from the grid and outputs it to the motor through the inverter, thereby converting the electrical energy into kinetic energy. When the load speed is greater than the output speed of the converter, or the entire belt needs to be braked and stopped by the rated speed, the converter needs to output an opposite braking force to the motor, the inverter side generates an excitation current, and the gravity pulls the motor to generate electricity. At this time, the motor becomes a generator, the generated electric energy reaches the DC bus of the converter to increase the DC bus voltage, and the PWM rectification system makes the phase of the input current opposite to the phase of the power supply voltage to reversely modulate the regenerative energy of the motor to the power grid to realize the energy regenerative braking of the motor, that is, the purpose of converting the kinetic energy of the belt into electrical energy is realized. The braking torque of the converter can reach 200% of the rated torque of the motor, which can ensure the stability of start and stop of the belt.

Selection Table

Description of SCHORCH Product Selection

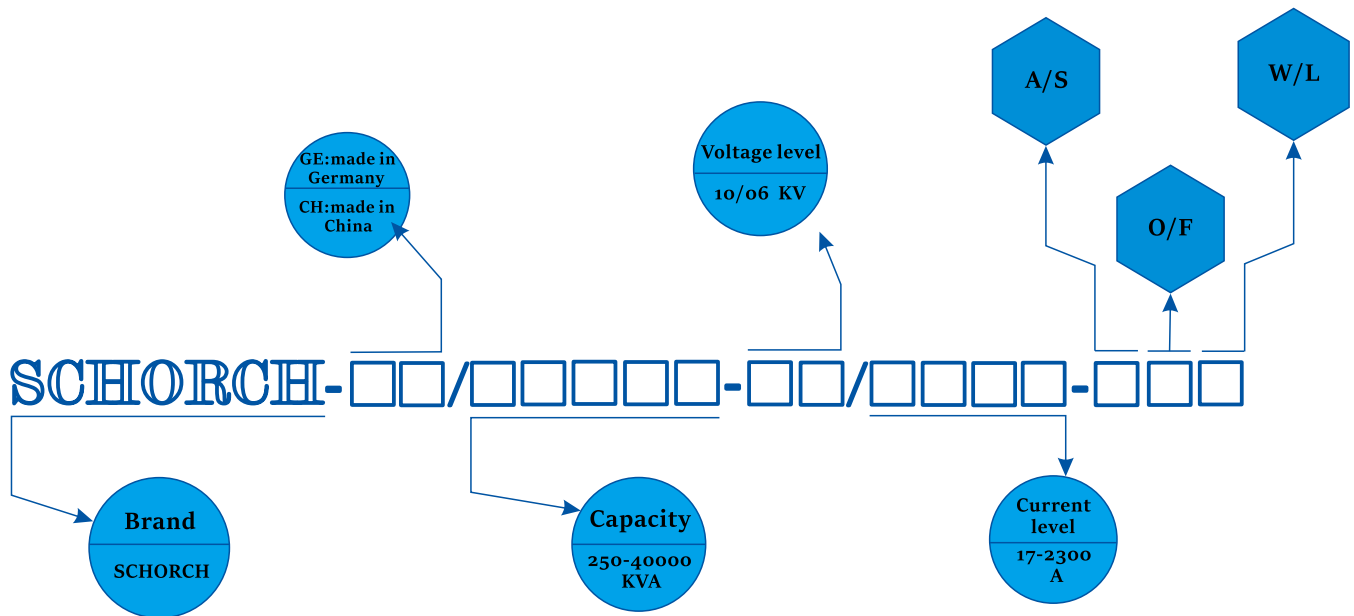

- A: asynchronous motor
- S: synchronous motor
- W: wind cooling
- L: liquid cooling
- O: quadrants of one and three
- F: quadrants of two and four



## Technical Data Sheet of Schorch Products

Items		Parameter Selection
Input	Input rated voltage	3、3.3、6、6.6、10KV(*)
	Voltage fluctuation range	Runs at full load with voltage fluctuation of $\pm 10\%$
	Frequency variation range	$50\text{Hz} \pm 10\%$
	Input power factor	$\geq 0.95$ (over 20% load)
	Input current harmonics	$\leq 5\%$ meeting standards of IEEE519-1992 and GB/T14549-93
Output	Output voltage range	3、3.3、6、6.6、10KV(*)
	Max. output capacity	30000KVA
	Output frequency range	0-50Hz(*)
Control mode	Main circuit mode	Directly connected in series with HV converter
	Control mode	Vector control with/without speed sensor, V/F control
	Output frequency resolution	0.01Hz
	Acceleration and deceleration time	1-3000s(*)
	Overload capacity	125% 60s
	Current limiting protection	150%
	Converter efficiency	$> 97\%$ (including input transformer)
	Main control functions	Patented function of power unit pre-charge, functions of efficient low-voltage speed regulation, flying start, restart after instantaneous stop, main circuit bypass, high and low voltage ride-through, abnormal detection of unit waveform and converter output waveform, and remote diagnosis.
	Protection functions	Overload, over current, abnormal output voltage (stop when deviation exceeds 30%), abnormal cooling fan, power failure detection, etc.
	Communication function	Hard wiring(standard) Profibus-DP(*), Modbus(*), Ethernet(*)
	Earthing resistance	$\leq 4\Omega$
MTBF	80000h	
Cabinet structure	Cabinet structure	Made of steel plate, self-supporting locking
	Cabinet protection level	Ip30(*)
	Seismic capacity (with base)	According to the 7-level shockproof design
	Cooling method	Forced air cooling
	Cabinet color	Standard RAL7035 light grey (*)
Environment	Temperature	Operating temperature: $-10\sim 40^{\circ}\text{C}$ , storage temperature: $-20\sim 60^{\circ}\text{C}$
	RH	$\text{RH} \leq 95\%$ (without condensation at $20^{\circ}\text{C}$ )
	Altitude	$\leq 1000\text{m}$ (*)
	Ground acceleration	$0.1\text{g}$ (*)
	Setting place	Indoor, general environment without corrosive, flammable, explosive gas (*)

## SCHORCH 6kV Specification Selection Table

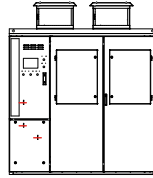

Product Name	Product Model	Adoptive Voltage KV	Adoptive Motor Power KW	Rated Current A	Overall Dimension mm	Weight kg
MV Convert	SCHORCH-CH/10000-6/900-AOW	6	8000	900	9987*1700*3357	20600
MV Convert	SCHORCH-CH/9000-6/820-AOW	6	7100	820	9987*1700*3357	20600
MV Convert	SCHORCH-CH/7875-6/750-AOW	6	6300	750	9987*1700*3357	20600
MV Convert	SCHORCH-CH/7500-6/710-AOW	6	6000	710	9987*1700*3357	20600
MV Convert	SCHORCH-CH/7000-6/675-AOW	6	5600	675	9387*1700*3056	20460
MV Convert	SCHORCH-CH/7000-6/650-AOW	6	5600	650	8887*1700*3056	19300
MV Convert	SCHORCH-CH/6750-6/645-AOW	6	5400	645	8887*1700*3056	19300
MV Convert	SCHORCH-CH/6250-6/600-AOW	6	5000	600	8887*1700*3056	19300
MV Convert	SCHORCH-CH/6000-6/578-AOW	6	4800	578	8887*1700*3056	19300
MV Convert	SCHORCH-CH/6250-6/560-AOW	6	5000	560	8887*1700*3056	19300
MV Convert	SCHORCH-CH/5625-6/545-AOW	6	4500	545	8887*1700*3056	19300
MV Convert	SCHORCH-CH/5500-6/530-AOW	6	4400	530	8887*1700*3056	19300
MV Convert	SCHORCH-CH/5625-6/522-AOW	6	4500	522	8887*1700*3056	19300
MV Convert	SCHORCH-CH/5250-6/505-AOW	6	4200	505	8887*1700*3056	19300
MV Convert	SCHORCH-CH/5000-6/480-AOW	6	4000	480	8087*1700*3056	13550
MV Convert	SCHORCH-CH/4750-6/458-AOW	6	3800	458	8087*1700*3056	13550
MV Convert	SCHORCH-CH/4750-6/440-AOW	6	3800	440	8087*1700*3056	13550
MV Convert	SCHORCH-CH/4440-6/430-AOW	6	3550	430	7262*1700*3056	13550
MV Convert	SCHORCH-CH/4440-6/400-AOW	6	3550	400	6356*1700*3056	12900
MV Convert	SCHORCH-CH/3940-6/380-AOW	6	3150	380	6356*1700*3056	12900
MV Convert	SCHORCH-CH/3940-6/365-AOW	6	3150	365	6356*1700*3056	12900
MV Convert	SCHORCH-CH/3750-6/360-AOW	6	3000	360	6356*1700*3056	12900
MV Convert	SCHORCH-CH/3500-6/338-AOW	6	2800	338	6056*1700*2722	10900
MV Convert	SCHORCH-CH/3500-6/325-AOW	6	2800	325	6056*1700*2722	10900
MV Convert	SCHORCH-CH/3125-6/305-AOW	6	2500	305	6056*1700*2722	10900
MV Convert	SCHORCH-CH/3000-6/280-AOW	6	2400	280	4854*1500*2687	8700
MV Convert	SCHORCH-CH/2800-6/270-AOW	6	2240	270	4854*1500*2687	8700
MV Convert	SCHORCH-CH/2750-6/265-AOW	6	2200	265	4854*1500*2687	8700
MV Convert	SCHORCH-CH/2750-6/255-AOW	6	2200	255	4854*1500*2687	8700
MV Convert	SCHORCH-CH/2650-6/250-AOW	6	2100	250	4854*1500*2687	8700
MV Convert	SCHORCH-CH/2500-6/240-AOW	6	2000	240	4854*1500*2687	8700
MV Convert	SCHORCH-CH/2250-6/218-AOW	6	1800	218	4854*1500*2687	8700

**SCHORCH 6kV  
Specification Selection Table**

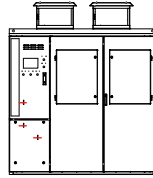

Product Name	Product Model	Adoptive Voltage KV	Adoptive Motor Power KW	Rated Current A	Overall Dimension mm	Weight kg
MV Convert	SCHORCH-CH/2250-6/203-AOW	6	1800	203	4854*1500*2687	6700
MV Convert	SCHORCH-CH/2000-6/195-AOW	6	1600	195	4854*1500*2687	6700
MV Convert	SCHORCH-CH/1850-6/180-AOW	6	1480	180	4854*1500*2687	5800
MV Convert	SCHORCH-CH/1750-6/170-AOW	6	1400	170	4854*1500*2687	5800
MV Convert	SCHORCH-CH/1400-6/135-AOW	6	1120	135	3652*1400*2687	5200
MV Convert	SCHORCH-CH/1250-6/120-AOW	6	1000	120	3352*1400*2687	5200
MV Convert	SCHORCH-CH/1190-6/115-AOW	6	950	115	3352*1400*2687	5200
MV Convert	SCHORCH-CH/1125-6/110-AOW	6	900	110	3352*1400*2687	5200
MV Convert	SCHORCH-CH/1600-6/152-AOW	6	1280	152	3652*1400*2687	4980
MV Convert	SCHORCH-CH/1565-6/150-AOW	6	1250	150	3652*1400*2687	4980
MV Convert	SCHORCH-CH/1065-6/105-AOW	6	850	105	3352*1400*2687	4980
MV Convert	SCHORCH-CH/1000-6/96-AOW	6	800	96	2400*1500*2442	4980
MV Convert	SCHORCH-CH/940-6/94-AOW	6	750	94	2400*1500*2442	4980
MV Convert	SCHORCH-CH/890-6/88-AOW	6	710	88	2400*1500*2442	4980
MV Convert	SCHORCH-CH/840-6/84-AOW	6	670	84	2400*1500*2442	4980
MV Convert	SCHORCH-CH/790-6/79-AOW	6	630	79	2400*1500*2442	3730
MV Convert	SCHORCH-CH/750-6/75-AOW	6	600	75	2400*1500*2442	3730
MV Convert	SCHORCH-CH/700-6/70-AOW	6	560	70	2100*1500*2442	3730
MV Convert	SCHORCH-CH/665-6/66-AOW	6	530	66	2100*1500*2442	3730
MV Convert	SCHORCH-CH/625-6/63-AOW	6	500	63	2100*1500*2442	3730
MV Convert	SCHORCH-CH/595-6/60-AOW	6	475	60	2100*1500*2442	3730
MV Convert	SCHORCH-CH/565-6/56-AOW	6	450	56	2100*1500*2442	3730
MV Convert	SCHORCH-CH/535-6/53-AOW	6	425	53	2100*1500*2442	3730
MV Convert	SCHORCH-CH/500-6/50-AOW	6	400	50	2100*1500*2442	3730
MV Convert	SCHORCH-CH/470-6/47-AOW	6	375	47	2100*1500*2442	3730
MV Convert	SCHORCH-CH/445-6/45-AOW	6	355	45	2100*1500*2442	3730
MV Convert	SCHORCH-CH/420-6/42-AOW	6	335	42	2100*1500*2442	3730
MV Convert	SCHORCH-CH/395-6/39-AOW	6	315	39	2100*1500*2442	3730
MV Convert	SCHORCH-CH/375-6/38-AOW	6	300	38	2100*1500*2442	3730
MV Convert	SCHORCH-CH/350-6/35-AOW	6	280	35	2100*1500*2442	3730
MV Convert	SCHORCH-CH/315-6/32-AOW	6	250	32	2100*1500*2442	3730
MV Convert	SCHORCH-CH/275-6/28-AOW	6	220	28	1800*1500*2390	3730
MV Convert	SCHORCH-CH/250-6/25-AOW	6	200	25	1800*1500*2390	3730

### SCHORCH 10kV Specification Selection Table

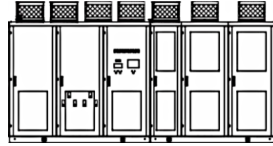

Product Name	Product Model	Adoptive Voltage	Adoptive Motor Power KW	Rated Current	Overall Dimension	Weight kg
MV VFD	SCHORCH-CH/15625-10/900-AOW	10KV	12500	900	18825*1700*3358	42160
MV VFD	SCHORCH-CH/15000-10/860-AOW	10KV	12000	860	18825*1700*3358	42160
MV VFD	SCHORCH-CH/14375-10/820-AOW	10KV	11500	820	18825*1700*3358	42160
MV VFD	SCHORCH-CH/13750-10/780-AOW	10KV	11000	780	18825*1700*3358	42160
MV VFD	SCHORCH-CH/13125-10/750-AOW	10KV	10500	750	18825*1700*3358	42160
MV VFD	SCHORCH-CH/12500-10/710-AOW	10KV	10000	710	18825*1700*3358	42160
MV VFD	SCHORCH-CH/11875-10/680-AOW	10KV	9500	680	18825*1700*3358	42160
MV VFD	SCHORCH-CH/11250-10/640-AOW	10KV	9000	640	16724*1700*3056	37350
MV VFD	SCHORCH-CH/10000-10/578-AOW	10KV	8000	578	11593*1700*3358	24950
MV VFD	SCHORCH-CH/10000-10/560-AOW	10KV	8000	560	11593*1700*3358	24950
MV VFD	SCHORCH-CH/9000-10/520-AOW	10KV	7100	520	11593*1700*3358	24950
MV VFD	SCHORCH-CH/9000-10/480-AOW	10KV	7100	480	10793*1700*3358	22600
MV VFD	SCHORCH-CH/7875-10/455-AOW	10KV	6300	455	9968*1700*3358	21600
MV VFD	SCHORCH-CH/7875-10/440-AOW	10KV	6300	440	9968*1700*3358	21600
MV VFD	SCHORCH-CH/7500/-10/435-AOW	10KV	6000	435	9968*1700*3358	21600
MV VFD	SCHORCH-CH/7500-10/405-AOW	10KV	6000	405	8460*1700*3358	21375
MV VFD	SCHORCH-CH/7000-10/400-AOW	10KV	5600	400	7860*1700*3056	18775
MV VFD	SCHORCH-CH/6750-10/390-AOW	10KV	5400	390	7860*1700*3056	18775
MV VFD	SCHORCH-CH/6750-10/365-AOW	10KV	5400	365	7860*1700*3056	18775
MV VFD	SCHORCH-CH/6250-10/360-AOW	10KV	5000	360	7860*1700*3056	18775
MV VFD	SCHORCH-CH/6000-10/350-AOW	10KV	4800	350	7860*1700*3056	18775
MV VFD	SCHORCH-CH/5625-10/320-AOW	10KV	4500	320	7860*1700*3056	18775
MV VFD	SCHORCH-CH/5500-10/315-AOW	10KV	4400	315	7860*1700*3056	18775
MV VFD	SCHORCH-CH/5250-10/305-AOW	10KV	4200	305	7860*1700*3056	18775
MV VFD	SCHORCH-CH/5000-10/280-AOW	10KV	4000	280	6557*1800*3052	12519
MV VFD	SCHORCH-CH/4750-10/275-AOW	10KV	3800	275	6557*1800*3052	12519
MV VFD	SCHORCH-CH/4750-10/255-AOW	10KV	3800	255	6557*1800*3052	12519
MV VFD	SCHORCH-CH/4440-10/250-AOW	10KV	3550	250	6557*1800*3052	12519
MV VFD	SCHORCH-CH/3940-10/230-AOW	10KV	3150	230	6557*1800*3052	12519
MV VFD	SCHORCH-CH/3750-10/218-AOW	10KV	3000	218	6557*1800*3052	12519
MV VFD	SCHORCH-CH/3750-10/205-AOW	10KV	3000	205	6257*1700*2722	10400
MV VFD	SCHORCH-CH/3500-10/200-AOW	10KV	2800	200	6257*1700*2722	10400
MV VFD	SCHORCH-CH/3125-10/180-AOW	10KV	2500	180	6257*1700*2722	10400
MV VFD	SCHORCH-CH/3000-10/175-AOW	10KV	2400	175	6257*1700*2722	10400
MV VFD	SCHORCH-CH/2800-10/165-AOW	10KV	2240	165	6257*1700*2722	10400
MV VFD	SCHORCH-CH/2750-10/160-AOW	10KV	2200	160	5152*1700*2722	9080
MV VFD	SCHORCH-CH/2800-10/155-AOW	10KV	2240	155	4554*1700*2722	8000
MV VFD	SCHORCH-CH/2750-10/152-AOW	10KV	2200	152	4554*1700*2722	8000



**SCHORCH 10kV  
Specification Selection Table**

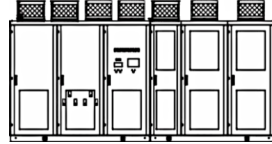

Product Name	Product Model	Adoptive Voltage	Adoptive Motor Power KW	Rated Current	Overall Dimension	Weight kg
MV VFD	SCHORCH-CH/2650-10/150-AOW	10KV	2100	150	4554*1700*2722	7000
MV VFD	SCHORCH-CH/2500-10/145-AOW	10KV	2000	145	2950*1700*2750	5500
MV VFD	SCHORCH-CH/2250-10/130-AOW	10KV	1800	130	2950*1700*2750	5500
MV VFD	SCHORCH-CH/2000-10/115-AOW	10KV	1600	115	2950*1700*2750	5500
MV VFD	SCHORCH-CH/1850-10/106-AOW	10KV	1480	106	2950*1700*2750	5500
MV VFD	SCHORCH-CH/1750-10/103-AOW	10KV	1400	103	2950*1700*2750	5000
MV VFD	SCHORCH-CH/1750-10/98-AOW	10KV	1400	98	2400*1500*2442	5000
MV VFD	SCHORCH-CH/1600-10/93-AOW	10KV	1280	93	2400*1500*2442	4500
MV VFD	SCHORCH-CH/1565-10/91-AOW	10KV	1250	91	2400*1500*2442	4500
MV VFD	SCHORCH-CH/1400-10/82-AOW	10KV	1120	82	2400*1500*2442	4500
MV VFD	SCHORCH-CH/1250-10/73-AOW	10KV	1000	73	2400*1500*2442	4000
MV VFD	SCHORCH-CH/1190-10/70-AOW	10KV	950	70	2100*1500*2442	4000
MV VFD	SCHORCH-CH/1125-10/66-AOW	10KV	900	66	2100*1500*2442	4000
MV VFD	SCHORCH-CH/1065-10/62-AOW	10KV	850	62	2100*1500*2442	4000
MV VFD	SCHORCH-CH/1000-10/58-AOW	10KV	800	58	2100*1500*2442	4000
MV VFD	SCHORCH-CH/940-10/56-AOW	10KV	750	56	2100*1500*2442	4000
MV VFD	SCHORCH-CH/890-10/53-AOW	10KV	710	53	2100*1500*2442	4000
MV VFD	SCHORCH-CH/840-10/49-AOW	10KV	670	49	2100*1500*2442	4000
MV VFD	SCHORCH-CH/790-10/47-AOW	10KV	630	47	2100*1500*2442	4000
MV VFD	SCHORCH-CH/750-10/45-AOW	10KV	600	45	2100*1500*2442	4000
MV VFD	SCHORCH-CH/700-10/42-AOW	10KV	560	42	2100*1500*2442	4000
MV VFD	SCHORCH-CH/665-10/40-AOW	10KV	530	40	2100*1500*2442	4000
MV VFD	SCHORCH-CH/625-10/38-AOW	10KV	500	38	2100*1500*2442	4000
MV VFD	SCHORCH-CH/595-10/36-AOW	10KV	475	36	2100*1500*2442	4000
MV VFD	SCHORCH-CH/565-10/34-AOW	10KV	450	34	2100*1500*2442	4000
MV VFD	SCHORCH-CH/535-10/32-AOW	10KV	425	32	2100*1500*2442	4000
MV VFD	SCHORCH-CH/500-10/29-AOW	10KV	400	29	1800*1500*2390	3500
MV VFD	SCHORCH-CH/470-10/28-AOW	10KV	375	28	1800*1500*2390	3500
MV VFD	SCHORCH-CH/445-10/27-AOW	10KV	355	27	1800*1500*2390	3500
MV VFD	SCHORCH-CH/420-10/25-AOW	10KV	335	25	1800*1500*2390	3500
MV VFD	SCHORCH-CH/395-10/24-AOW	10KV	315	24	1800*1500*2390	3500
MV VFD	SCHORCH-CH/375-10/23-AOW	10KV	300	23	1800*1500*2390	3500
MV VFD	SCHORCH-CH/350-10/21-AOW	10KV	280	21	1800*1500*2390	3500
MV VFD	SCHORCH-CH/315-10/19-AOW	10KV	250	19	1800*1500*2390	3500
MV VFD	SCHORCH-CH/275-10/17-AOW	10KV	220	17	1800*1500*2390	3500
MV VFD	SCHORCH-CH/250-10/15-AOW	10KV	200	15	1800*1500*2390	3500

Remarks:

1. Please contact and consult our commercial staff for the selection of converters with other input and output voltages.
2. Please consult our technical staff for the selection of larger capacity.
3. Only domestic models are marked in the models. For imported models, please contact our commercial staff.